



Additional display WD-4/1 in cooperation with measuring indicator series PUE C/31. Data displayed on the additional display are identical to those presented on the indicator of weighing instrument. WD-4/1 : ABS plastic casing, cable with input DB9.

Basic features:

- automatic detection of speed of transmission
- automatic switch off
- LCD backlight
- power supply from measuring indicator (scale)

Additional display WD-3/01 in cooperation with scales PS, PS/X, XA/X, AS/X, AS, APP and APP/X.

Basic features:

- automatic switch off
- LCD backlight
- power supply from measuring indicator (scale)

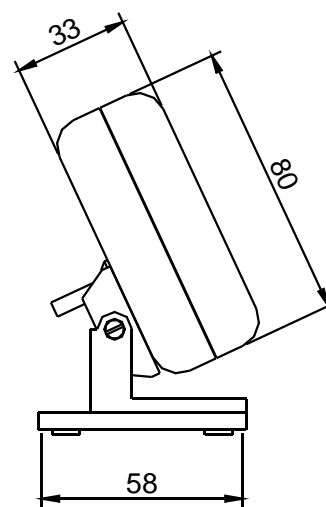
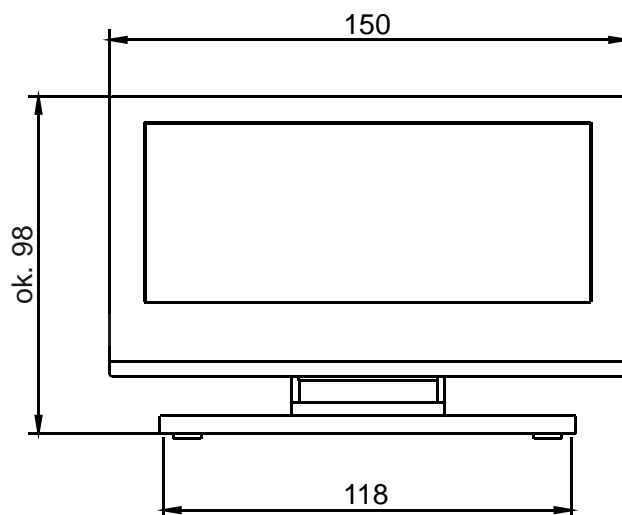
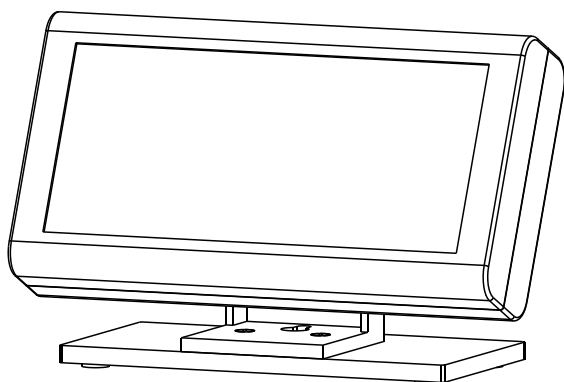

Specification:

Power supply	6V DC from measuring indicator (scale)
Digit size	19 mm
Connection cable length	1,5 m
Dimensions	150 × 80 × 33 *

* dimensions do not include cable chokes and holders for mounting